

Rise Above Space Constraints!

Often, a project requires the power of a crane, but the limited space pervasive to nuclear utilities makes using one costly and time-consuming. To tackle this problem, PSC's engineers leveraged the law of physics and their technical knowledge to design an innovative solution: the patent-pending Scorpion System. The Scorpion's frame uses friction to support the crane on a single wall within a building or on an exterior structure to virtually eliminate the typical ground-level footprint required for a crane. A compressive load applied to both sides of the wall maintains positive engagement at all times.

Time & Cost Savings

- Eliminates the need for a pre-installed crane base, counterweights and core-drilling
- Installs in a single work shift and relocates quickly as a single unit
- Requires only minor surface preparation and no structural alterations to the wall or existing components

Patent-Pending Design

- Compact design requires wall length of less than 10 feet
- The frame extends vertically less than 4 feet from the top of the wall
- Independent downriggers accommodate variances in the wall thickness
- Custom modifications can be made to meet a nuclear plant's specific needs

Powerful Capacity

The Scorpion System can be custom-configured to meet a broad spectrum of loading, lifting and handling tasks.

- Maximum Overturning Moment of the crane with an FOS \approx 2
- Maximum Moment: 4,000 pounds at 71 feet
- Maximum Winch Capacity: ~8,000 pounds (single-part line), ~16,000 pounds (two-part line)



Safe, Seamless Operation

Wireless controls provide the operator with increased mobility to safely control load handling. The Scorpion System's safety features include:

- 360-degree load handling capacity
- An automated synchronous control system
- Detached hydraulic power unit that provides convenient access to power controls
- Wall clamping force that is continuously monitored by load cells with a digital readout unit

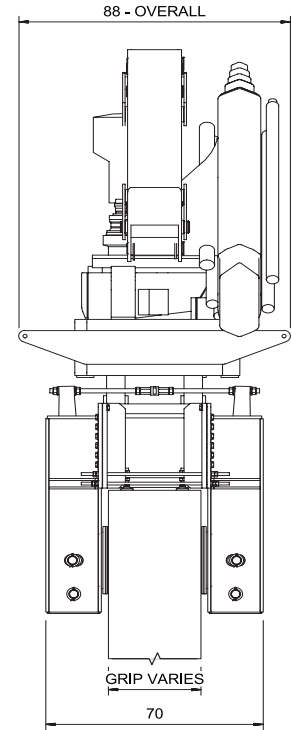
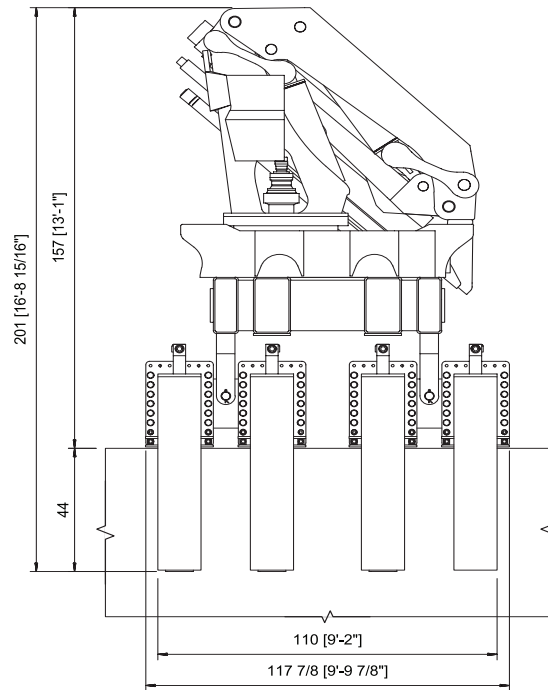
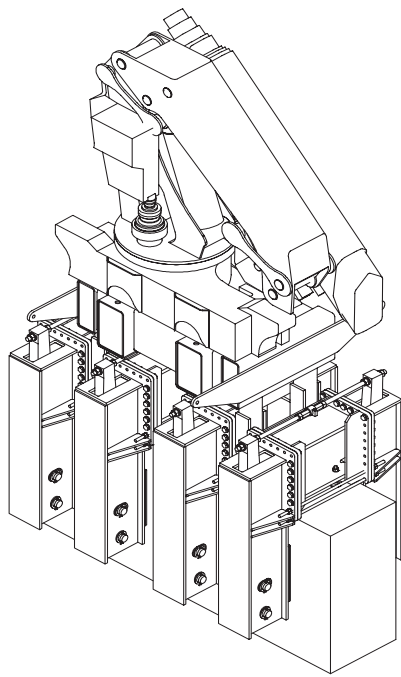

Crane Horizontal Load Capacity

